

System: Laufschiene aufgeschraubt, keine Nut im Boden, mit Blende, Laufwerk mit Clip, für 2 – 3 Holztüren bis 16 kg. Design Forslide mit Dämpfung in Laufschiene integriert

System: Running track surface mounted, no groove in the floor, without panel, running gear with clip, for 2 – 3 wooden doors up to 16 kg. Design Forslide with soft closing system integrated in running track

Système: rail de roulement vissé en applique, aucune rainure dans le sol, avec cache, chariot de roulement à clipser, pour 2 – 3 portes en bois jusqu'à 16 kg. Design Forslide avec amortissement intégré au rail de roulement

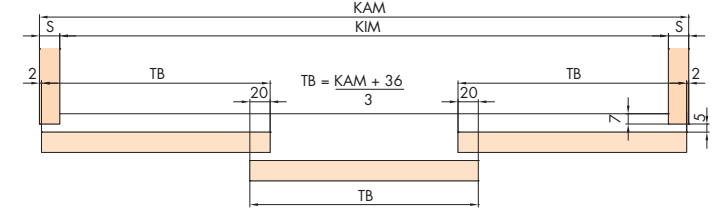
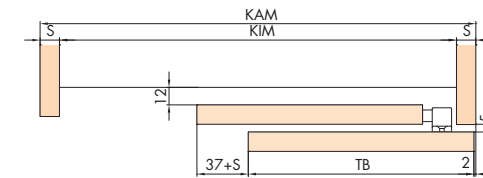
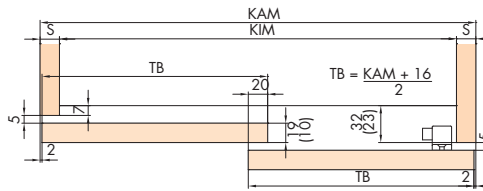
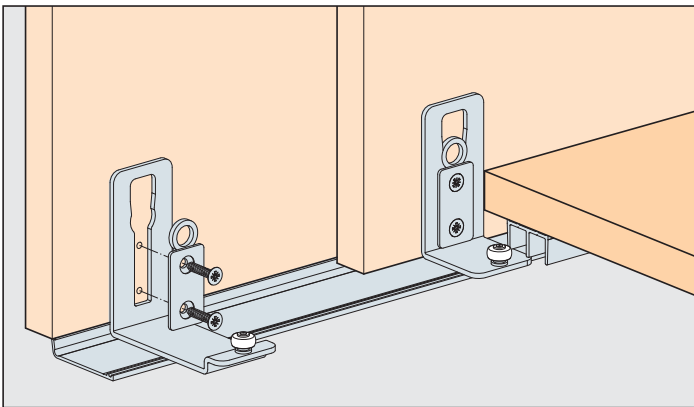

Einbau Muffe/Sleeve mounting/Montage de manchon

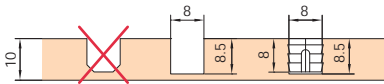

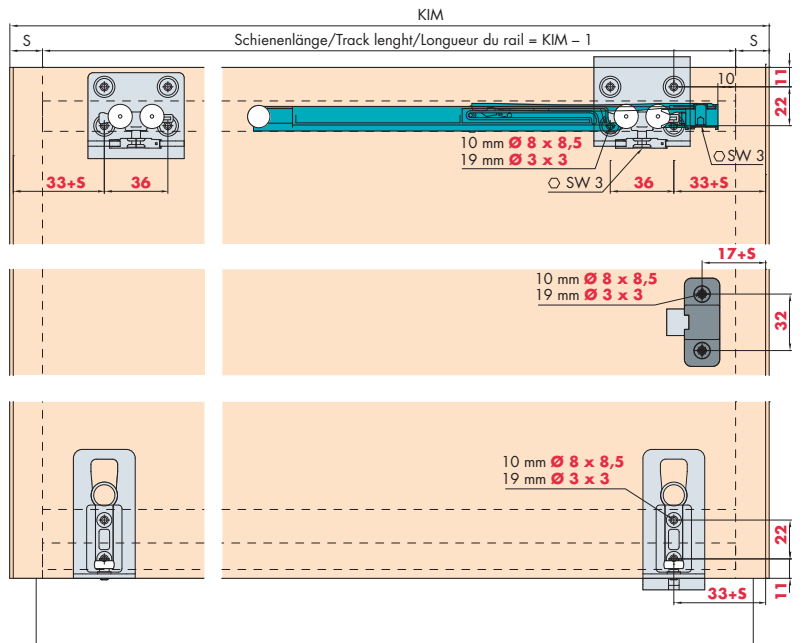
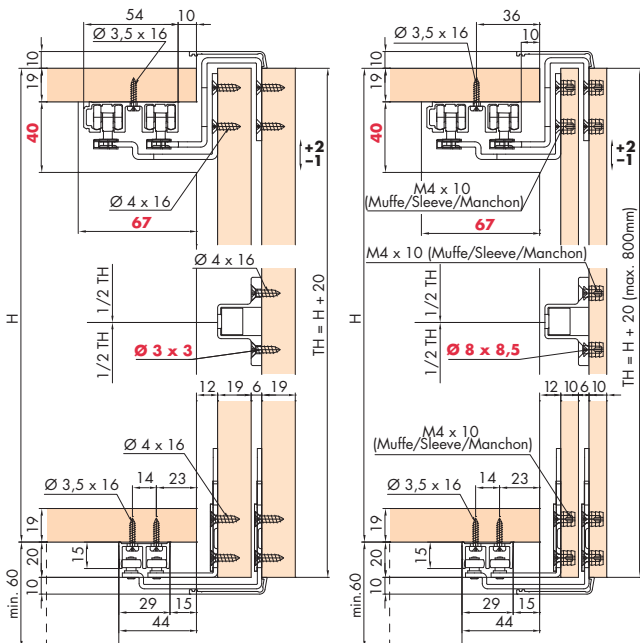

Einbaubeispiele/Mounting examples/Exemples de montage



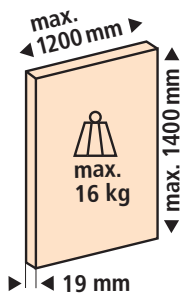



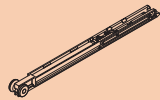
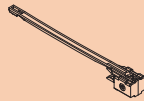



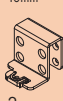



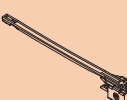

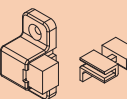



Garnituren / Sets / Garnitures

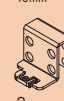

Türgewichte
Door weights
Poids de portes **69**

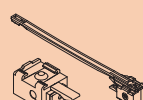
10 mm No. 053.3373.071
19 mm No. 053.3373.072
 2x
 2x
 2x
Für zusätzliches Dämpfen in Öffnungsrichtung 1 x bestellen. Order 1x for additional soft closing function in opening direction. Commander 1x pour un amortissement supplémentaire dans le sens de l'ouverture.

2 Türen Doors Portes	10mm No. 053.3374.071	 2x
	19mm No. 053.3374.072	
	10mm  2x	19mm  2x
	 2x	 2x
	 2x	 4x
	 1x	 1x
	 26x	

3 Türen Doors Portes	10mm No. 053.3375.071	 3x
	19mm No. 053.3375.072	
	10mm  2x	19mm  2x
	 4x	 4x
	 1x	 6x
	 36x	 2x
		

Zubehör / Accessories / Accessoires

Doppelaufschiene, Alu eloxiert, gelocht, zum Schrauben
Double running track, aluminium anodized, pre-drilled, for screw fixing
Rail de roulement double, en alu anodisé, perforé, à visser

Gr./Size	Art. No.
2500 mm	053.3339.250
3500 mm	053.3339.350
6000 mm	053.3339.600

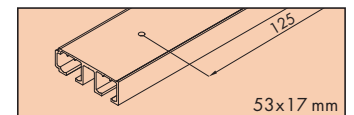

Doppelführungsschiene, Alu eloxiert, gelocht, zum Schrauben
Double guide track, aluminium anodized, pre-drilled, for screw fixing
Rail de guidage double, alu anodisé, perforé, à visser

2200 mm	053.3261.220
2400 mm	053.3261.240
4800 mm	053.3261.480

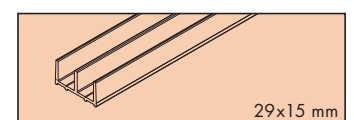

Abdeckprofil, Alu eloxiert, oben/unten**
Cover profile, aluminium anodized, top/bottom**
Profil de recouvrement, en alu anodisé, haut/bas**

2500 mm	056.3122.250
6000 mm	056.3122.600

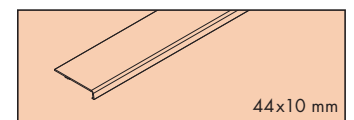

**** 2 mm Doppelklebeband verwenden / Use 2 mm double-sided adhesive tape / Utiliser un 2 mm ruban adhésif à double face**

Sonderzubehör / Special accessories / Accessoires spéciaux: ☞ 64-66